

Fulflo® MP (Membrane Protectors) Filter Vessels Protect Membranes by Prefiltering R.O. Feed Water

MP Filter Vessels are ideal for a wide range of filtration applications including prefiltration of brackish, process and sea water. All MP Series vessels are built in accordance with ASME Boiler and Pressure Vessel Code, U stamp. All MP vessels have dual purpose bottom seats for use with either double-open-end or 222 O-ring design.

Applications

- Brackish and Sea Water
- Semiconductor Process Water
- Boiler Feed Water
- Reverse Osmosis Prefiltration
- Potable Water
- Electronic Rinse Water
- Deionized Water



Features and Benefits

- Flow rates from 108 gpm to 3520 gpm.
- Pressure ratings from 100 psi (6.9 bars) to 150 psi (10.3 bars).
- 304L or 316L stainless steel.
- Stainless steel welded attachments.
- Swing bolt closure for quick opening, with hex nuts for use with pneumatic tools.
- Optional stainless steel bolting and davit assembly.
- Horizontal vessels provide for easy cartridge installation.
- Dual purpose cartridge seats for use with double open end and 2-222 O-ring single open end cartridges.
- Glassbead blasted exteriors.
- Passivated interior and exterior surfaces to remove free carbon and protect against corrosion.
- Buna-N O-ring closure seal provides positive cover sealing.
- Horizontal vessel utilizes removable internal cartridge support plate.
- Large size clean and dirty drain for uniform piping and valve size.

Process Filtration Division



Fulflo® MP Filter Vessels Throughput
Based on flow of water (in gpm) per 10 in cartridge

10 in Cartridges	Filter Model	At 3 gpm** per 10 in (gpm)* (mgd)*		At 3.5 gpm per 10 in (gpm) (mgd)		At 4 gpm per 10 in (gpm) (mgd)		At 4.5 gpm per 10 in (gpm) (mgd)		At 5 gpm per 10 in (gpm) (mgd)	
Vertical Vessels											
36	MP12-3-3FK1	108	0.2	126	0.2	144	0.2	162	0.2	180	0.3
48	MP12-4-4FK1	144	0.2	168	0.2	192	0.3	216	0.3	240	0.3
63	MP21-3-4FK1	189	0.3	221	0.3	252	0.4	284	0.4	315	0.5
84	MP21-4-4FK1	252	0.4	294	0.4	336	0.5	378	0.5	420	0.6
87	MP29-3-4FK1	261	0.4	305	0.4	348	0.5	392	0.6	435	0.6
105	MP35-3-6FK1	315	0.5	368	0.5	420	0.6	473	0.7	525	0.8
116	MP29-4-6FK1	348	0.5	406	0.6	464	0.7	522	0.8	580	0.8
120	MP40-3-6FK1	360	0.5	420	0.6	480	0.7	540	0.8	600	0.9
140	MP35-4-6FK1	420	0.6	490	0.7	560	0.8	630	0.9	700	1.0
156	MP52-3-6FK1	468	0.7	546	0.8	624	0.9	702	1.0	780	1.1
160	MP40-4-6FK1	480	0.7	560	0.8	640	0.9	720	1.0	800	1.2
208	MP52-4-8FK1	624	0.9	728	1.0	832	1.2	936	1.3	1040	1.5
258	MP86-3-8FK1	774	1.1	903	1.3	1032	1.5	1161	1.7	1290	1.9
309	MP103-3-8FK1	927	1.3	1082	1.6	1236	1.8	1391	2.0	1545	2.2
344	MP86-4-10FK1	1032	1.5	1204	1.7	1376	2.0	1548	2.2	1720	2.5
412	MP103-4-10FK1	1236	1.8	1442	2.1	1648	2.4	1854	2.7	2060	3.0
472	MP118-4-12FK1	1416	2.0	1652	2.4	1888	2.7	2124	3.1	2360	3.4
704	MP176-4-14FK1	2112	3.0	2464	3.5	2816	4.1	3168	4.6	3520	5.1
Horizontal Vessels											
120	MP40H-3-6FK1	360	0.5	420	0.6	480	0.7	540	0.8	600	0.9
156	MP52H-3-6FK1	468	0.7	546	0.8	624	0.9	702	1.0	780	1.1
160	MP40H-4-6FK1	480	0.7	560	0.8	640	0.9	720	1.0	800	1.2
208	MP52H-4-8FK1	624	0.9	728	1.0	832	1.2	936	1.3	1040	1.5
258	MP86H-3-8FK1	774	1.1	903	1.3	1032	1.5	1161	1.7	1290	1.9
309	MP103H-3-8FK1	927	1.3	1082	1.6	1236	1.8	1391	2.0	1545	2.2
344	MP86H-4-10FK1	1032	1.5	1204	1.7	1376	2.0	1548	2.2	1720	2.5
412	MP103H-4-10FK1	1236	1.8	1442	2.1	1648	2.4	1854	2.7	2060	3.0
472	MP118H-4-12 FK1	1416	2.0	1652	2.4	1888	2.7	2124	3.1	2360	3.4
704	MP176H-4-14FK1	2112	3.0	2464	3.5	2816	4.1	3168	4.6	3520	5.1

* gpm = gallons per minute

mgd = millions of gallons per day

** Actual flow rate is dependent on fluid viscosity, micron rating, contaminant and media type. Consult flow charts for each application.

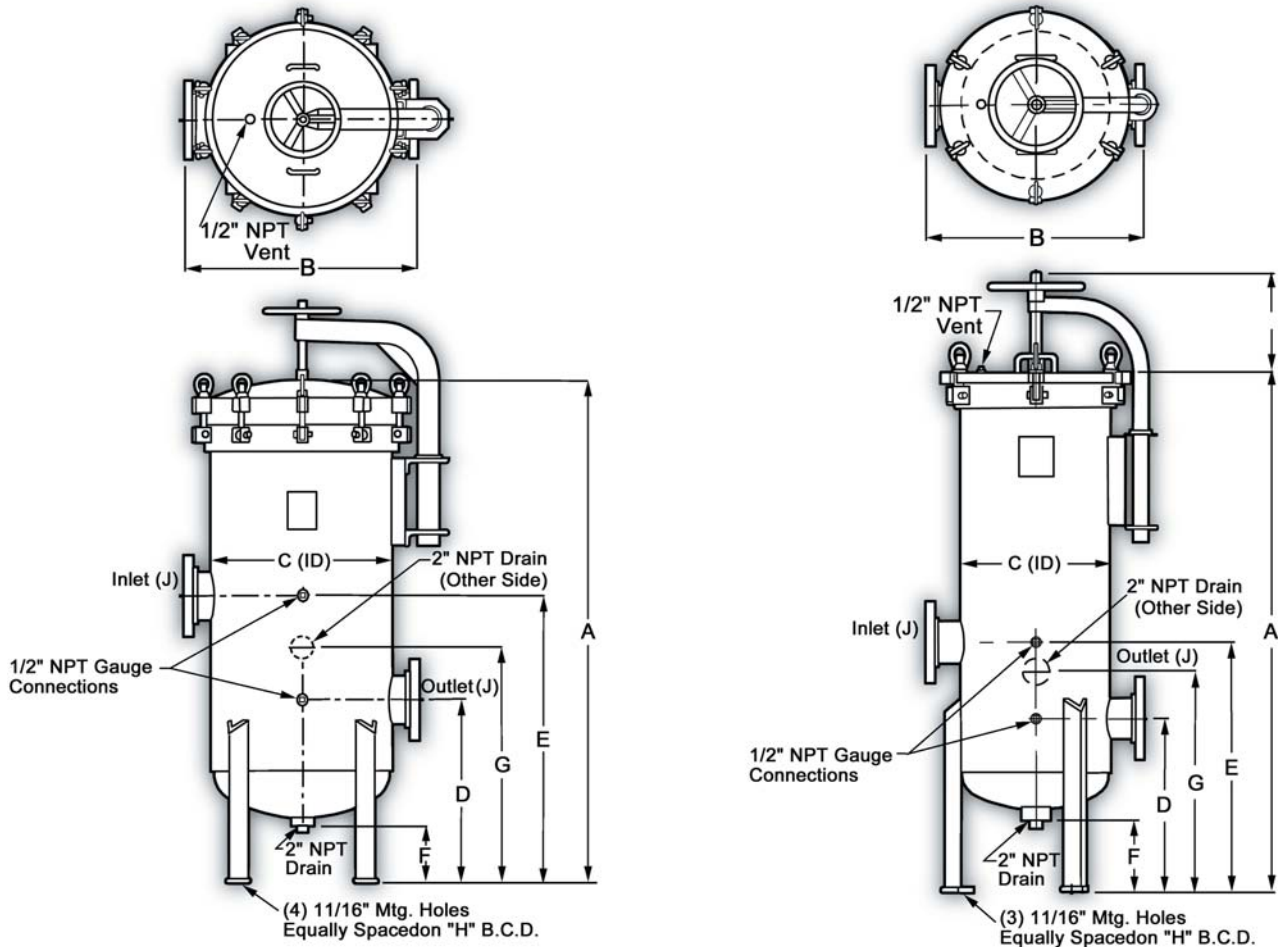

Design Specifications

Model	No. & Length of Cartridges (in)	Dimensions (in)			A	B	C	D	E	F	G	H	J	K	Shipping Weight (lbs)
MP12-3-3FK1	(12) 30	67.75	20.00	12.813	18.50	27.00	8.00	23.75	12.50	3 NPS	3	390			
MP12-4-4FK1	(12) 40	77.75	20.00	12.813	18.50	27.00	8.00	23.75	12.50	4 NPS	3	420			
MP21-3-4FK1	(21) 30	68.75	24.00	16.063	19.25	27.75	8.00	24.50	15.75	4 NPS	3	500			
MP21-4-4FK1	(21) 40	78.75	24.00	16.063	19.25	27.75	8.00	24.50	15.75	4 NPS	3	530			
MP29-3-4FK1	(29) 30	75.25	26.00	18.063	22.00	33.25	8.00	28.25	17.88	4 NPS	3	570			
MP29-4-6FK1	(29) 40	85.25	26.00	18.063	22.00	33.25	8.00	28.25	17.88	6 NPS	3	620			
MP35-3-6FK1	(35) 30	76.00	28.00	20.063	22.50	34.00	8.00	28.75	19.88	6 NPS	3	650			
MP35-4-6FK1	(35) 40	86.00	28.00	20.063	22.50	34.00	8.00	28.75	19.88	6 NPS	3	680			
MP40-3-6FK1	(40) 30	77.00	30.00	22.063	23.00	34.25	8.00	29.25	21.88	6 NPS	4	710			
MP40-4-6FK1	(40) 40	87.00	30.00	22.063	23.00	34.25	8.00	29.25	21.88	6 NPS	4	750			
MP52-3-6FK1	(52) 30	80.75	32.00	24.063	25.50	40.00	8.00	32.75	23.75	6 NPS	4	790			
MP52-4-8FK1	(52) 40	90.75	32.00	24.063	25.50	40.00	8.00	32.75	23.75	8 NPS	4	860			
MP86-3-8FK2	(86) 30	86.75	40.00	30.063	29.00	46.50	8.00	37.75	30.00	8 NPS	4	1280			
MP86-4-10FK2	(86) 40	96.75	40.00	30.063	29.00	46.50	8.00	37.75	30.00	10 NPS	4	1380			
MP103-3-8FK2	(103) 30	87.75	42.00	32.063	29.50	47.00	8.00	38.25	32.00	8 NPS	4	1410			
MP103-4-10FK2	(103) 40	97.75	42.00	32.063	29.50	47.00	8.00	38.25	32.00	10 NPS	4	1510			
MP118-4-12FK2	(118) 40	102.00	46.00	36.063	32.50	52.25	8.00	42.00	35.88	12 NPS	4	1830			
MP176-4-14FK2	(176) 40	107.00	54.00	42.063	35.00	57.00	8.00	45.50	42.00	14 NPS	4	2650			

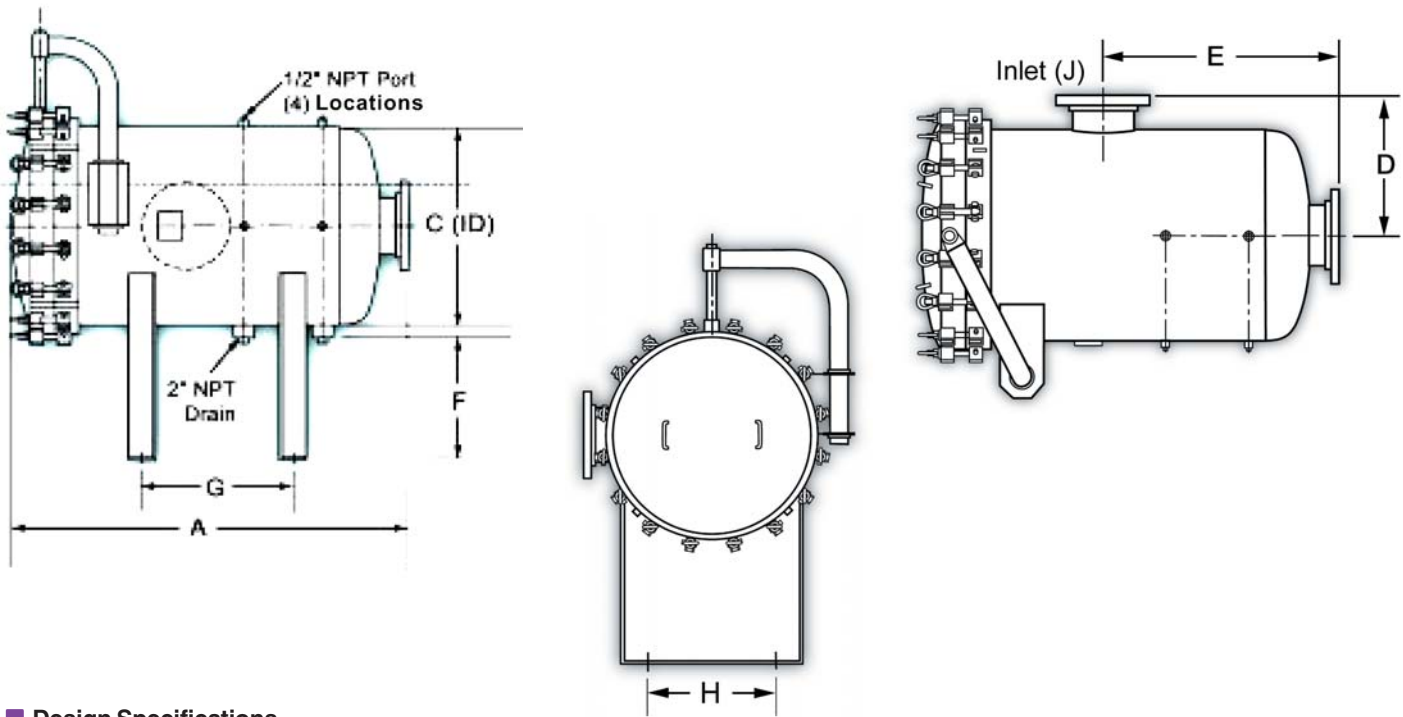

Design Specifications

Model	Elements (in)	Dimensions (in)			D	E	F	G	H	J	Shipping Weight (lbs)
		A	B	C							
MP40H-3-6FKI	(40) 30	55.50	62.00	22.063	15.00	32.00	23.00	23.00	12.00	6 NPS	850
MP40H-4-6FKI	(40) 40	65.50	62.00	22.063	15.00	36.00	23.00	32.00	12.00	6 NPS	880
MP52H-3-6FKI	(52) 30	55.25	63.00	24.063	16.00	32.00	22.00	23.00	14.00	6 NPS	920
MP52H-4-8FKI	(52) 40	65.25	63.00	24.063	16.00	36.00	22.00	32.00	14.00	8 NPS	990
MP86H-3-8FKI	(86) 30	60.25	66.00	30.063	20.00	34.00	19.00	24.00	20.00	8 NPS	1490
MP86H-4-10FKI	(86) 40	68.25	66.00	30.063	20.00	38.00	19.00	32.00	20.00	10 NPS	1560
MP103H-3-8FKI	(103) 30	60.75	67.00	32.063	21.00	34.00	18.00	24.00	22.00	8 NPS	1620
MP103H-4-10FKI	(103) 40	68.75	67.00	32.063	21.00	38.00	18.00	32.00	22.00	10 NPS	1700
MP118H-4-12FKI	(118) 40	72.00	69.00	36.063	23.00	40.00	16.00	32.00	26.00	12 NPS	2040
MP176H-4-14FKI	(176) 40	74.75	72.00	42.063	27.00	41.00	13.00	32.00	32.00	14 NPS	2820

Ordering Information

4 | **MP** | **40** | **3** | **6F** | **K1**
 Material | Design Series | Number of Columns | Cartridge Length (x 10 in) | Inlet/Outlet | Coverlift

4L = 304L SS
 6L = 316L SS
 MP = Vertical Series
 (12-176 Columns)
 MPXXH = Horizontal Series
 (40-176 Columns)

F = Flange
 No Symbol = None
 K1 = Mechanical
 K2 = Hydraulic

Process Filtration Division

